

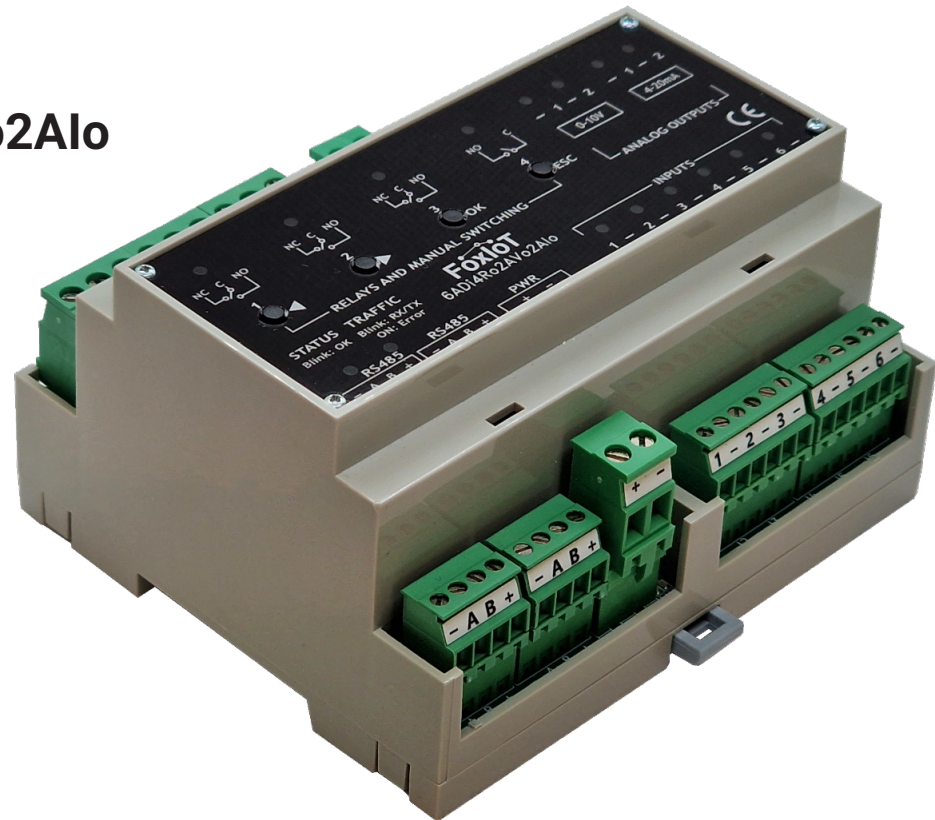

FoxIoT 6ADi4Ro2AVo2Alo Wiring Instructions

Wiring Reference and
Connection Guide for
Installers and System
Integrators



Modbus & Power Connection Contents

1. Foxlot 6Ai6Ro Modbus Connection Diagram with Shared Power Supply
2. Foxlot 6Ai6Ro Modbus Connection Diagram with Separate Power Supplies for Master and Relay Controllers

6ADi4Ro2AVo2Alo Output Connection Contents

3. Connecting a Contactor With 24V DC Coil to Controller Output
4. Connecting Lights to Controller Output
5. Connecting Motor to Controller Output
6. Connecting a Contactor with 230V AC coil to Controller Output
7. Connecting Multi-Speed AC Motors (up to 6 speeds) with Direct Relay Mapping to Controller Output
8. Connecting Multi-Speed AC Motors (3 speed) for Various Applications to Controller Output
9. Connecting External Automation System Inputs to Controller Outputs 1/2
10. Connecting External Automation System Inputs to Controller Outputs 2/2
11. Connecting Electromagnetic Locks and Electromagnetic Door Closers to 6AiRo outputs
12. Connecting Electric Strikes and Solenoid Door Locks to Controller Outputs for Secure Access Control
13. Connecting AC Curtain Motors to Controller Outputs
14. Connecting DC Curtain Motors to Controller Outputs

6ADi4Ro2AVo2Alo Input Connection Contents

15. Connecting 0-10V Output
16. Connecting 4..20mA Output with Separate Power Supply
17. Connecting 4..20mA Output with Shared Power Supply
18. Connecting a Switch or Relay Using Internal Pull-Up
19. Connecting a Switch or Relay with Sourcing Signal and External Pull-Down
20. Connecting Sink-Type Outputs (Open-Collector or Open-Drain) to a Controller Input
21. Connecting an NTC 10k Temperature Sensor to Controller Input

6ADi4Ro2AVo2Alo Analog Output Connection Contents

22. Connecting VFDs (0–10 V) to Analog Output Channels
23. Connecting LED Dimmers (0–10 V) to Analog Output Channels
24. Connecting 3-Way or 4-Way Valves (0–10 V or 4–20 mA)
25. Sending Analog Signals to External PLCs or Controllers (0–10 V / 4–20 mA)

FoxIot 6ADi4Ro2AVo2Io Modbus Connection Diagram with Shared Power Supply

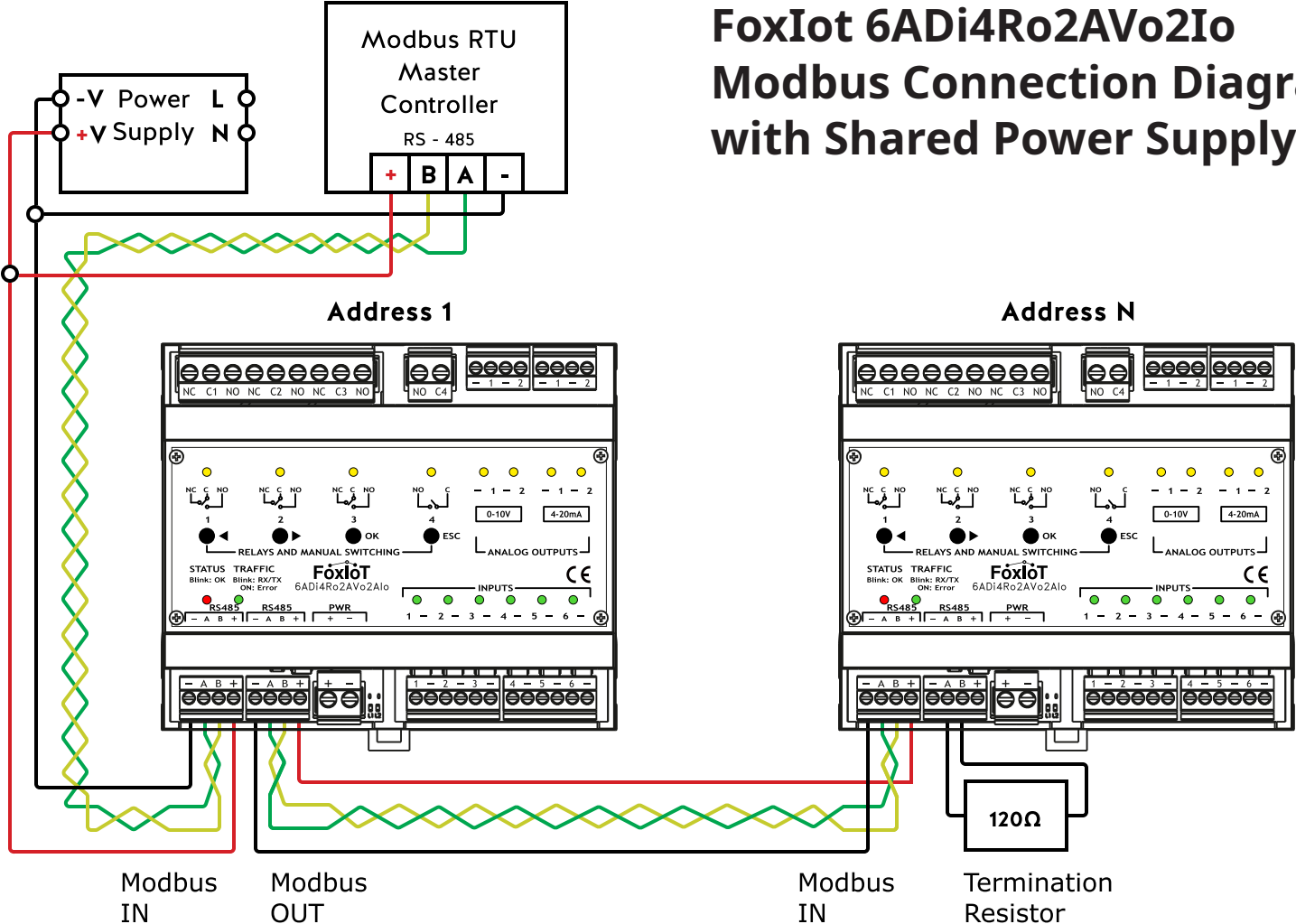

FoxIoT 6ADi4Ro2AVo2AIo Modbus Connection Diagram with Separate Power Supplies for Master and Relay Controllers

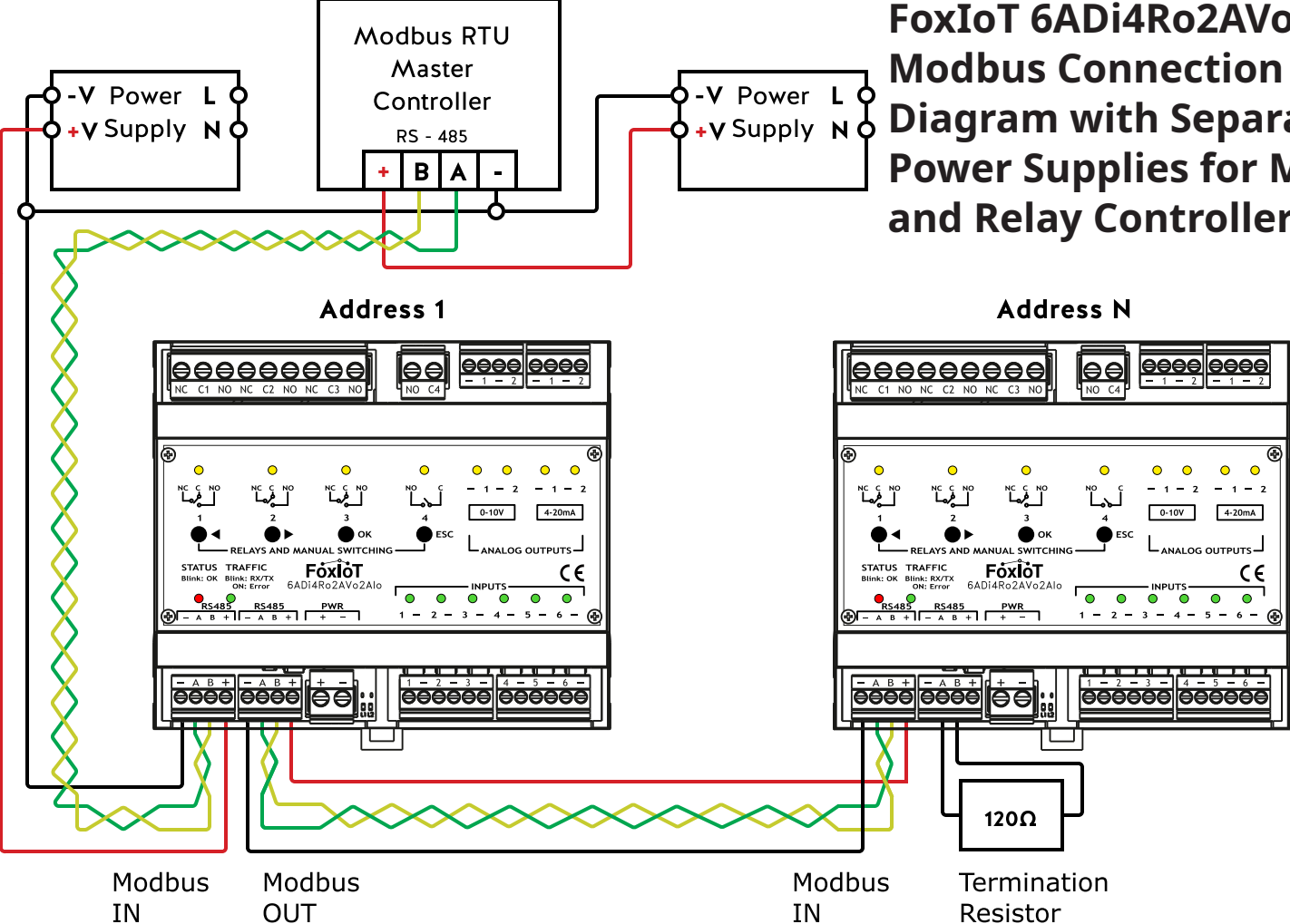

Connecting Lights to Controller Output

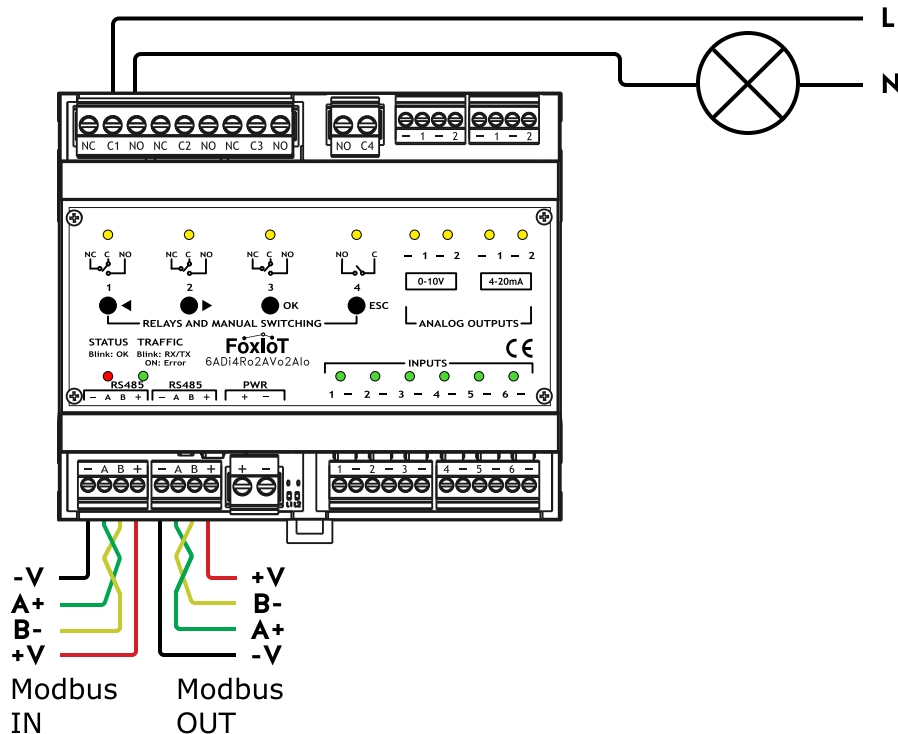

Note: Lights can be connected to any Relay port

Caution: When connecting modern LED lights, be aware of their capacitive load. Ensure the relay can handle the inrush current to avoid damage.

6ADi4Ro2AVo2Alo output connections

Connecting Motor to Controller Output

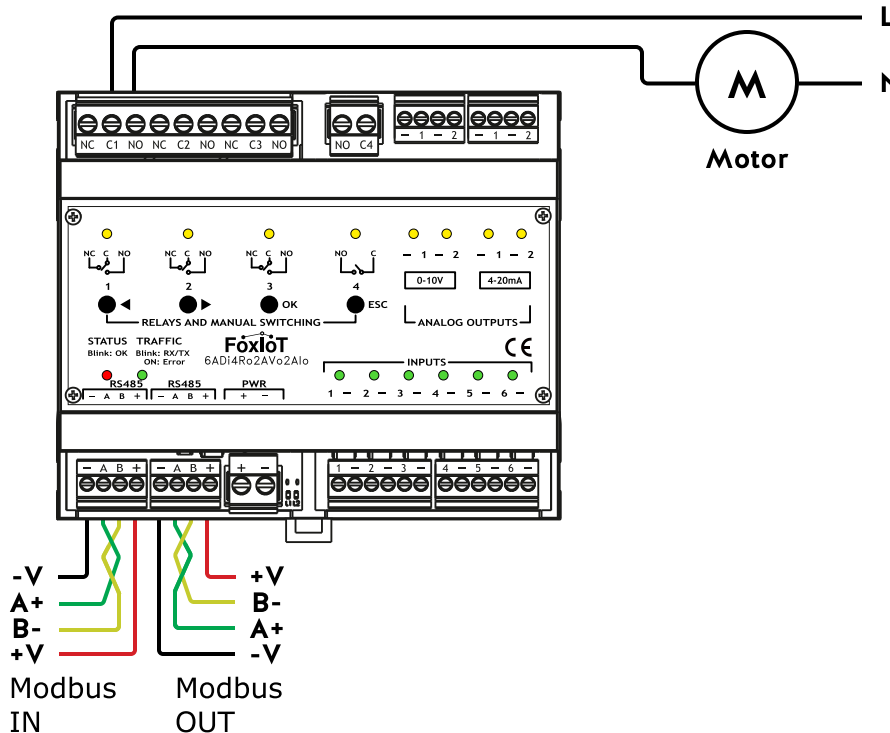

Note: Motors can be connected to any Relay port

Caution: Motors are inductive loads and can cause high inrush currents, especially during startup. Ensure the relay can handle the inductive load and inrush current.

6ADi4Ro2AVo2Alo output connections

Connecting a Contactor with 230V AC coil to Controller Output

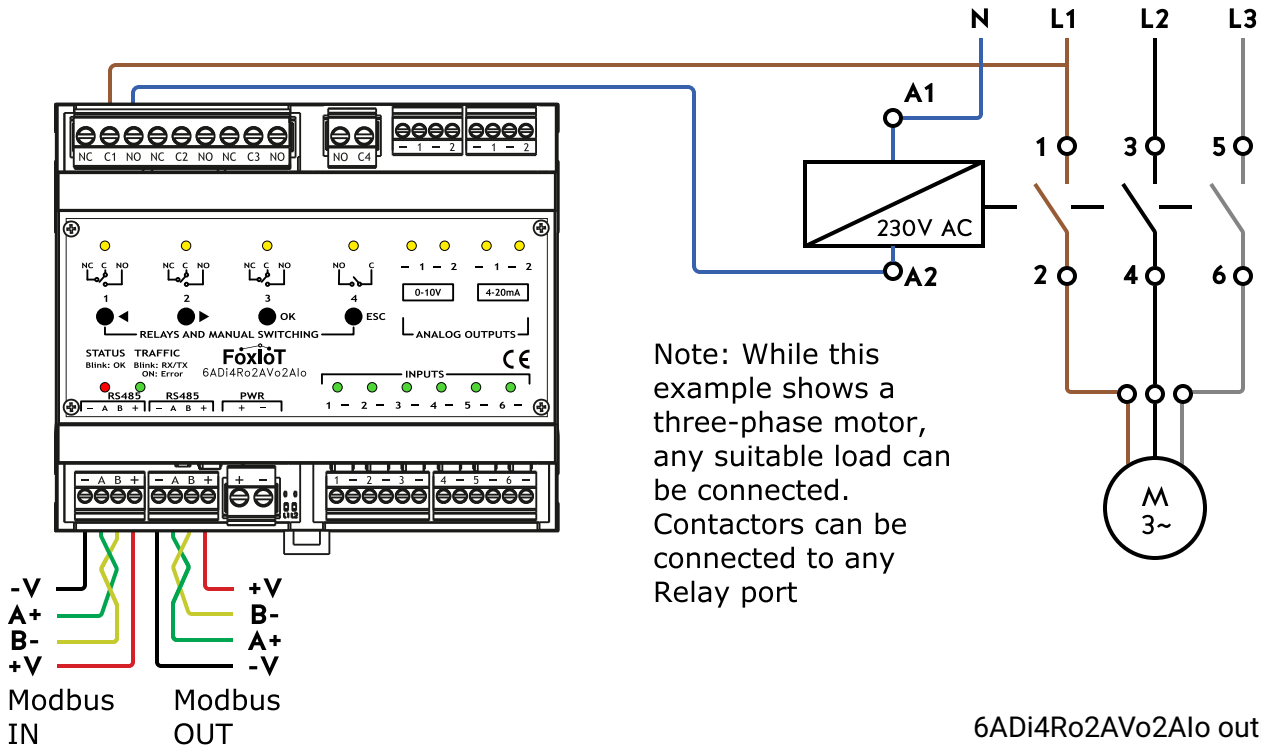

Note: While this example shows a three-phase motor, any suitable load can be connected to any Relay port

6ADi4Ro2AVo2Alo output connections

Connecting Multi-Speed AC Motors (up to 4 speeds) with Direct Relay Mapping to Controller Output

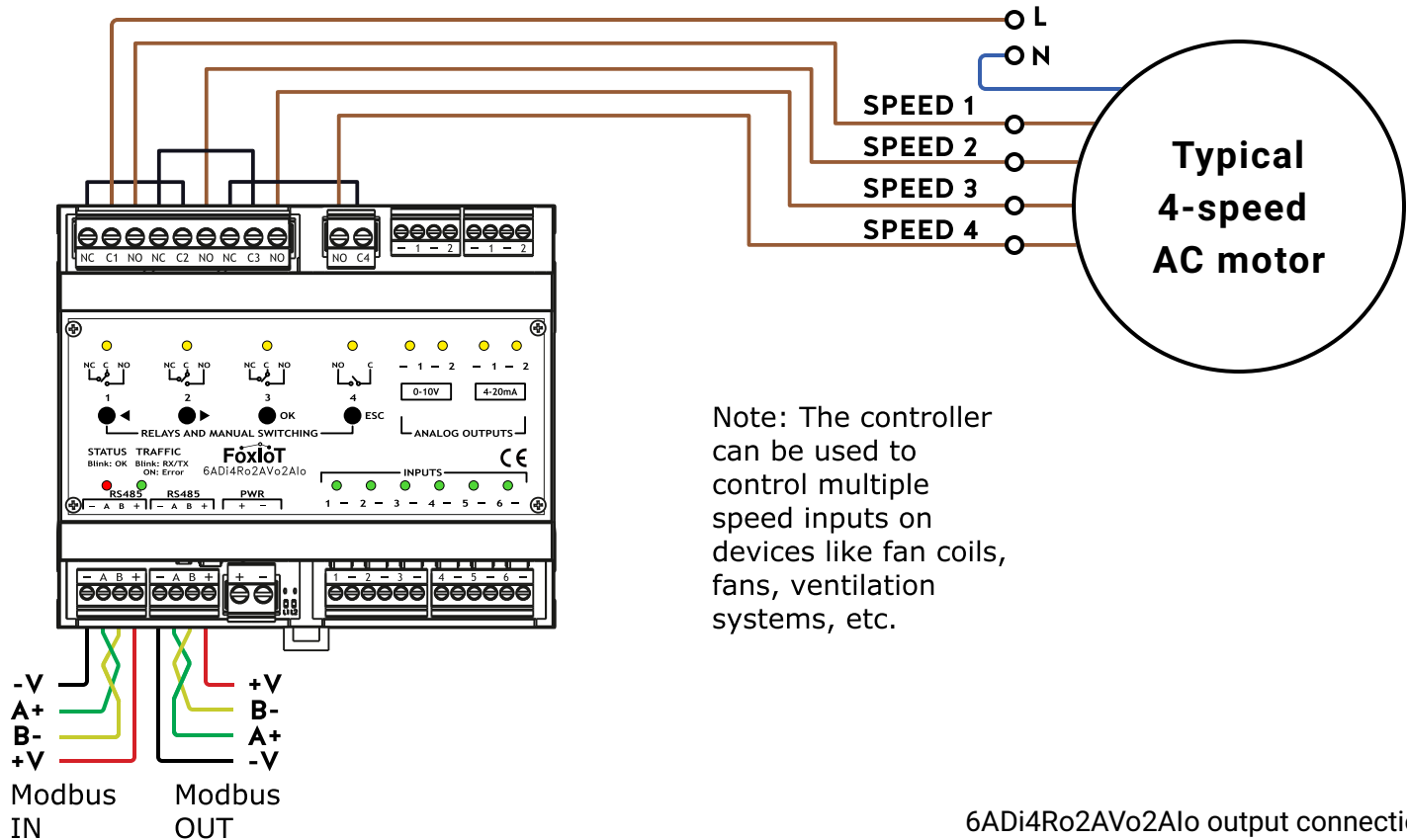

Connecting Multi-Speed AC Motors (3 speed) for Various Applications to Controller Output

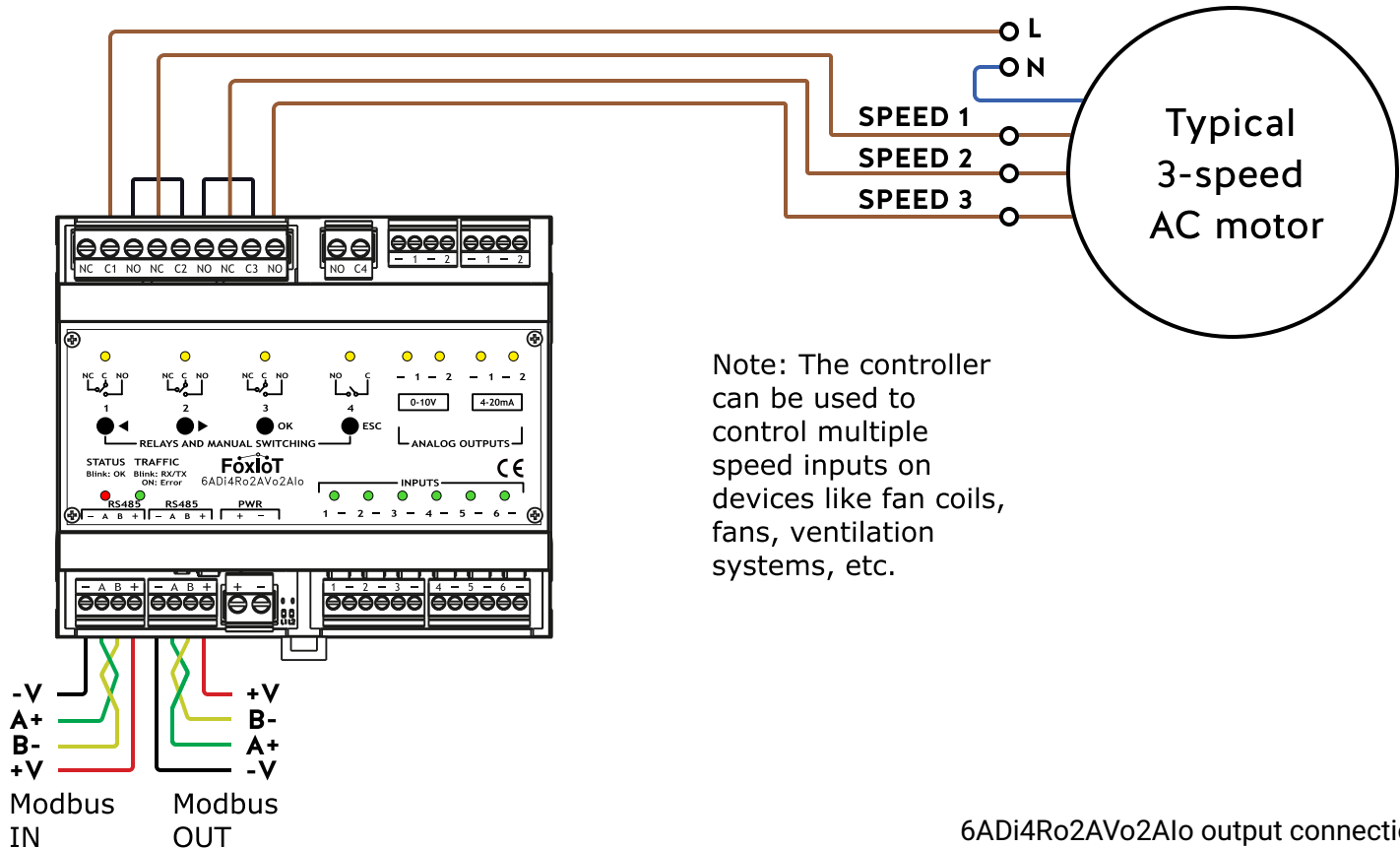

6ADi4Ro2AVo2Al0 output connections

Connecting External Automation System Inputs to Controller Outputs 1 / 2

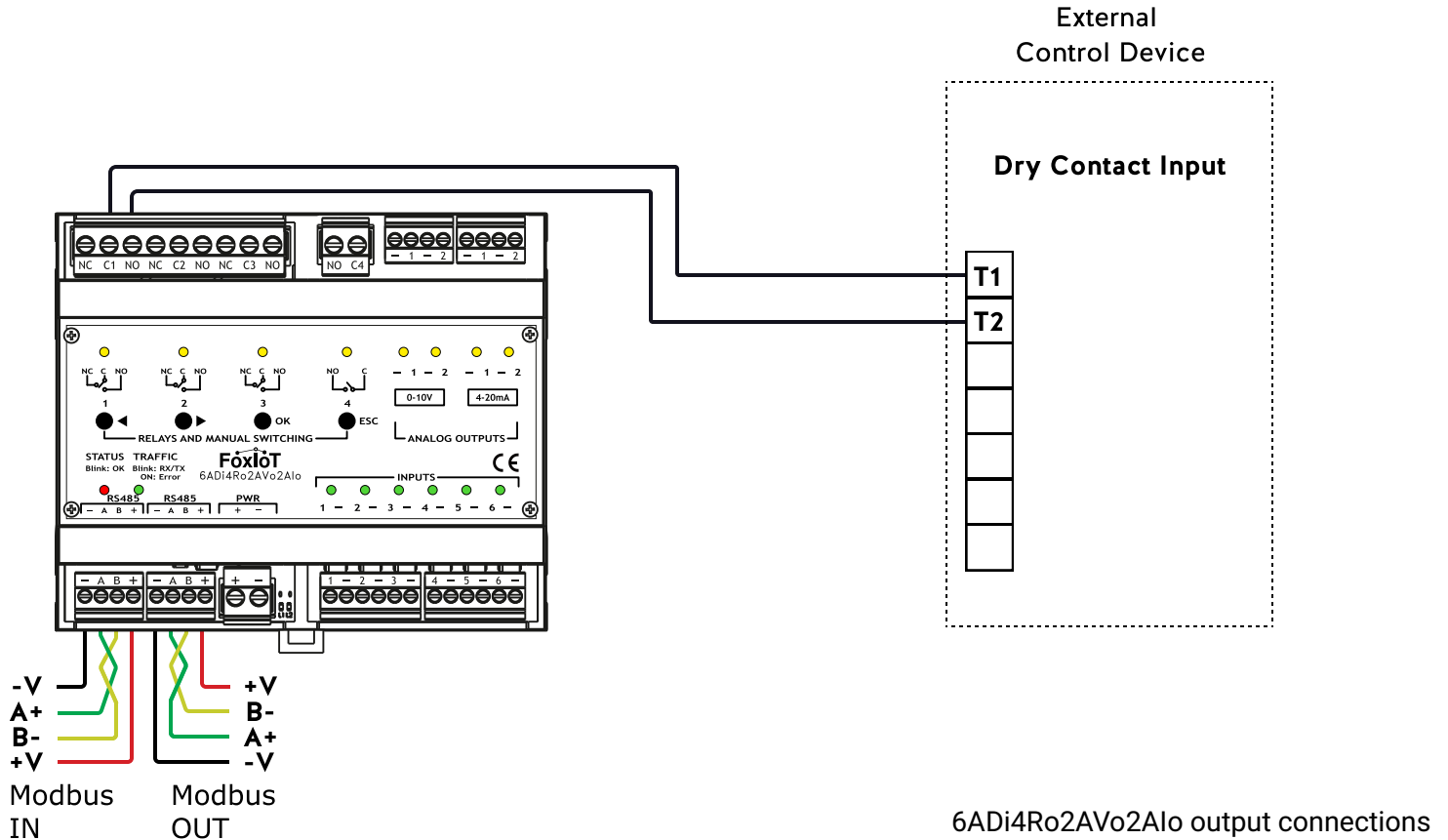

Connecting External Automation System Inputs to Controller Outputs 2/2

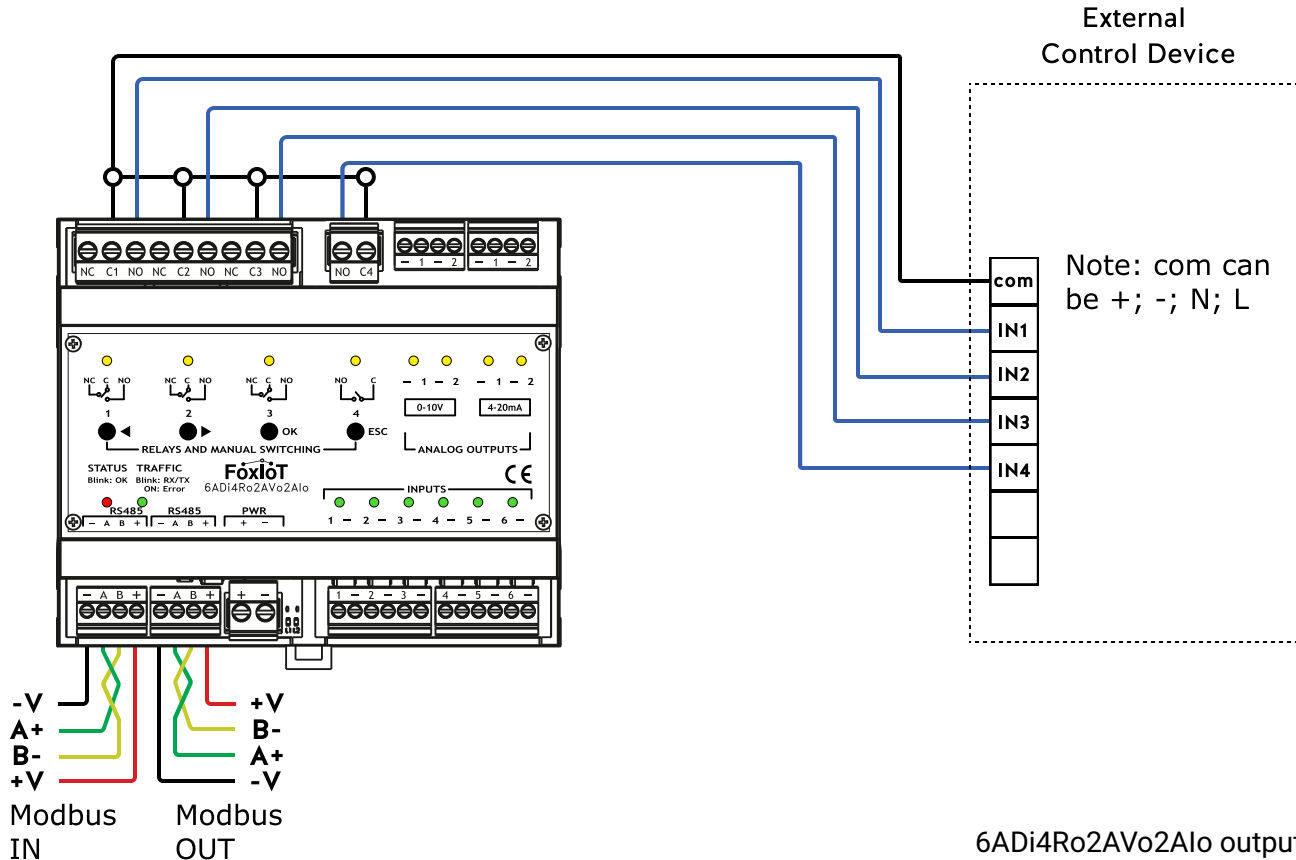

Connecting Electromagnetic Locks and Electromagnetic Door Closers to Controller Outputs

Note: Locks can be connected to any relay port

Note: Select the power supply voltage based on the magnetic lock operating voltage.

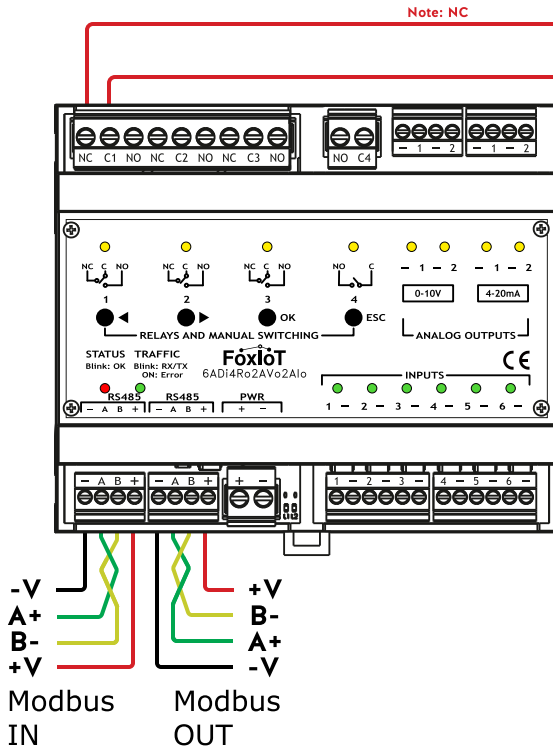

Note: NC

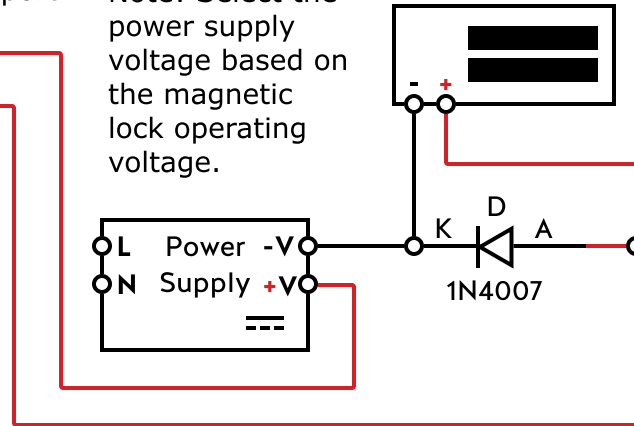

Note: To protect the relay from damage caused by voltage spikes when switching an electromagnet, place a diode across the electromagnet terminals.

Note: Door status - power on

6ADi4Ro2AVo2Alo output connections

Connecting Electric Strikes and Solenoid Door Locks to Controller Outputs for Secure Access Control

Note: Locks can be connected to any relay port

Note: Select the power supply voltage based on the magnetic lock operating voltage.

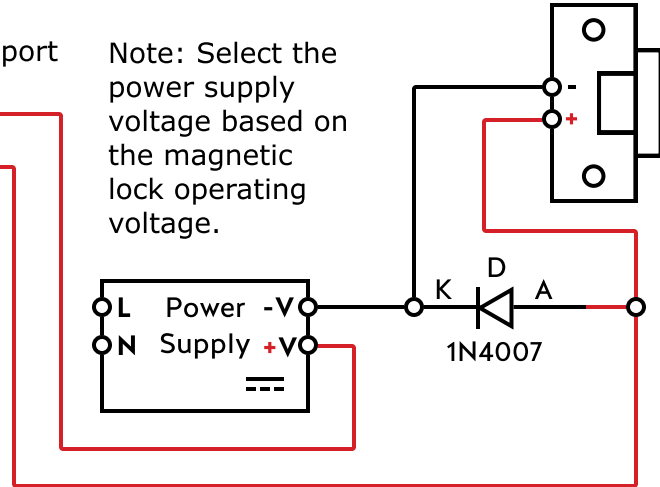
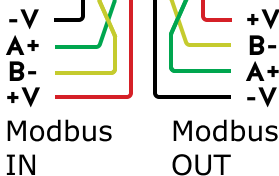
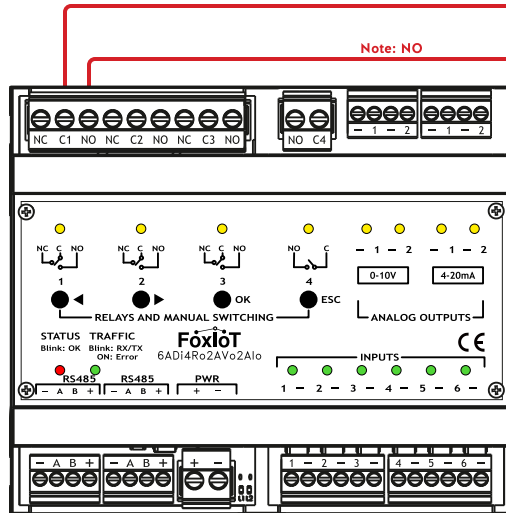

Note: To protect the relay from damage caused by voltage spikes when switching an electromagnet, place a diode across the electromagnet terminals.

Note: Locked status - power off

6ADi4Ro2AVo2Al0 output connections

Connecting AC Curtain Motors to Controller Outputs

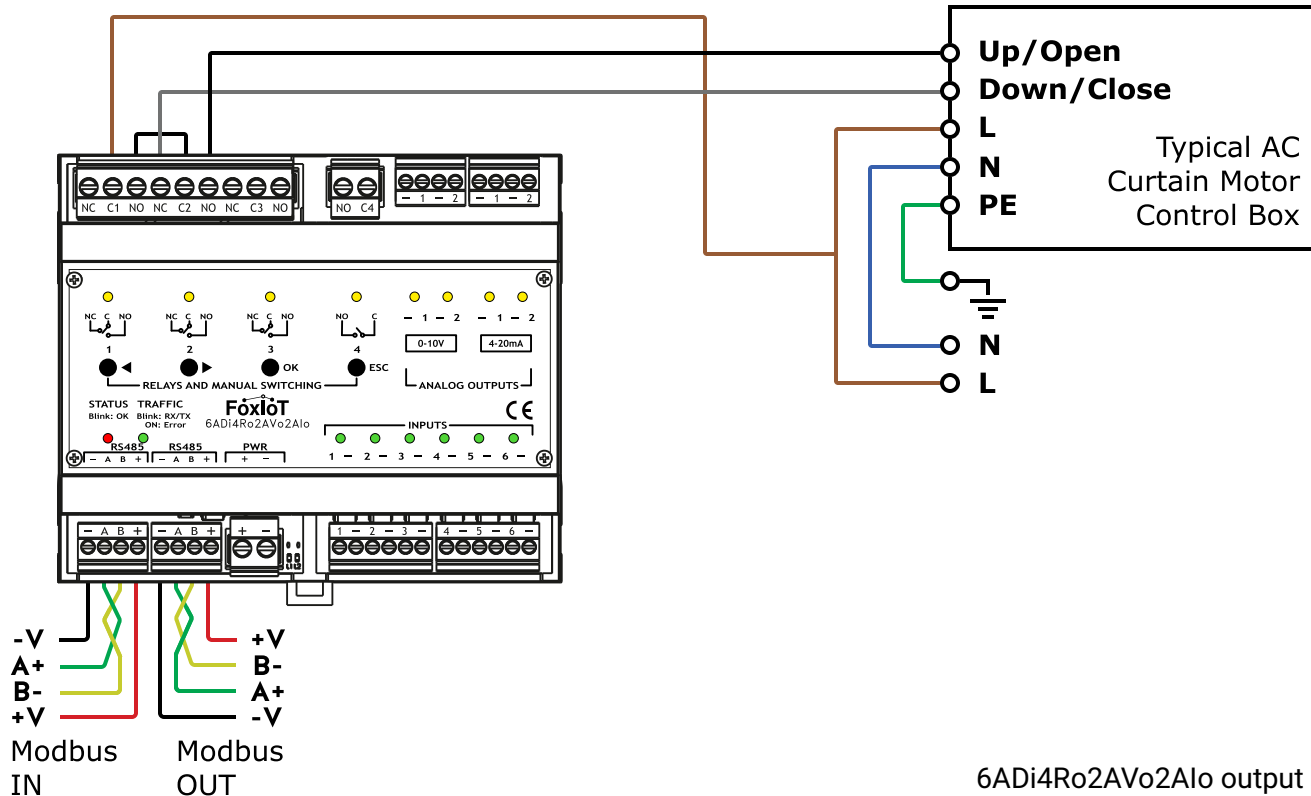

Connecting DC Curtain Motors to Controller Outputs

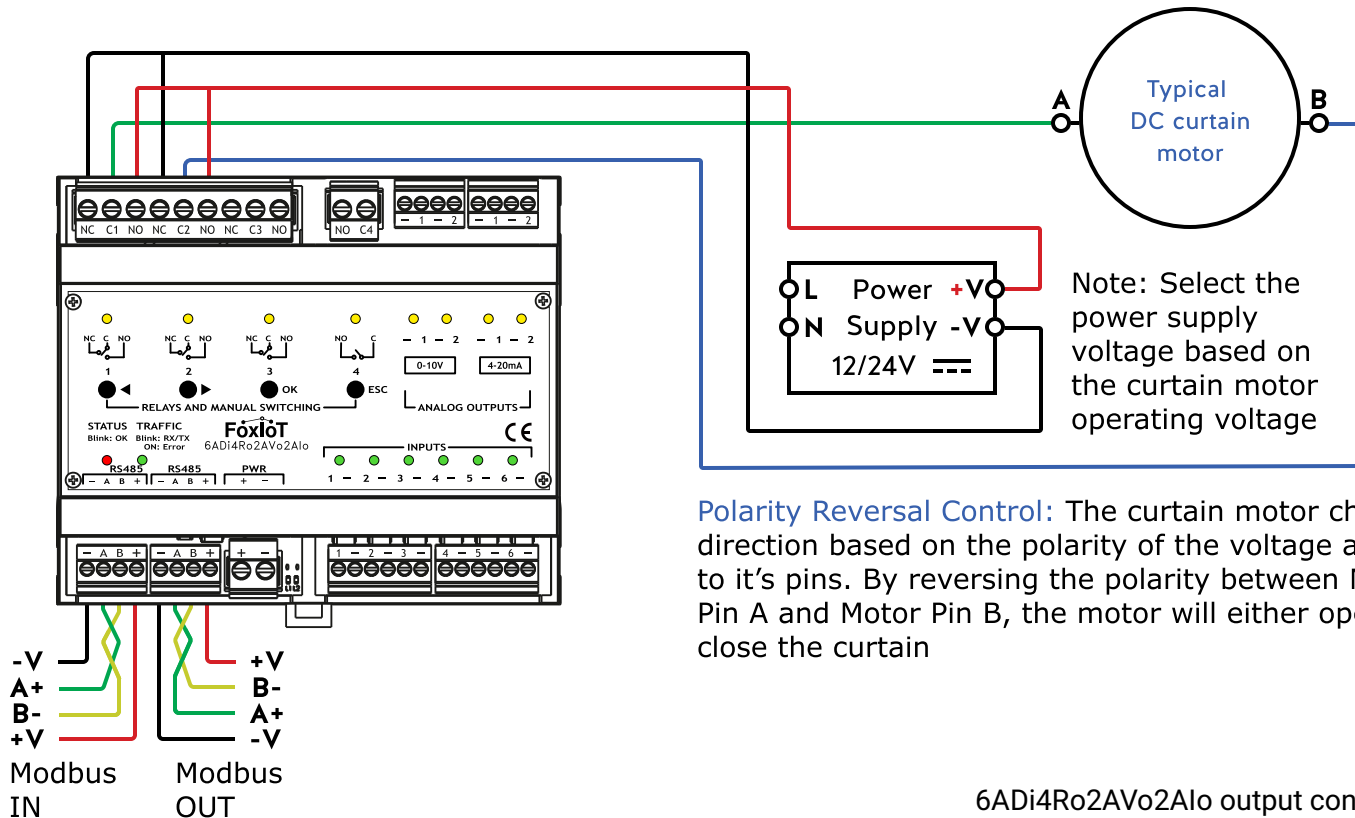

Polarity Reversal Control: The curtain motor changes direction based on the polarity of the voltage applied to it's pins. By reversing the polarity between Motor Pin A and Motor Pin B, the motor will either open or close the curtain

6ADi4Ro2AVo2Alo output connections

Connecting 0-10V Output

Set Port Mode 1 in Modbus Register (see datasheet)
Note: The 0-10V output can be connected to any input part

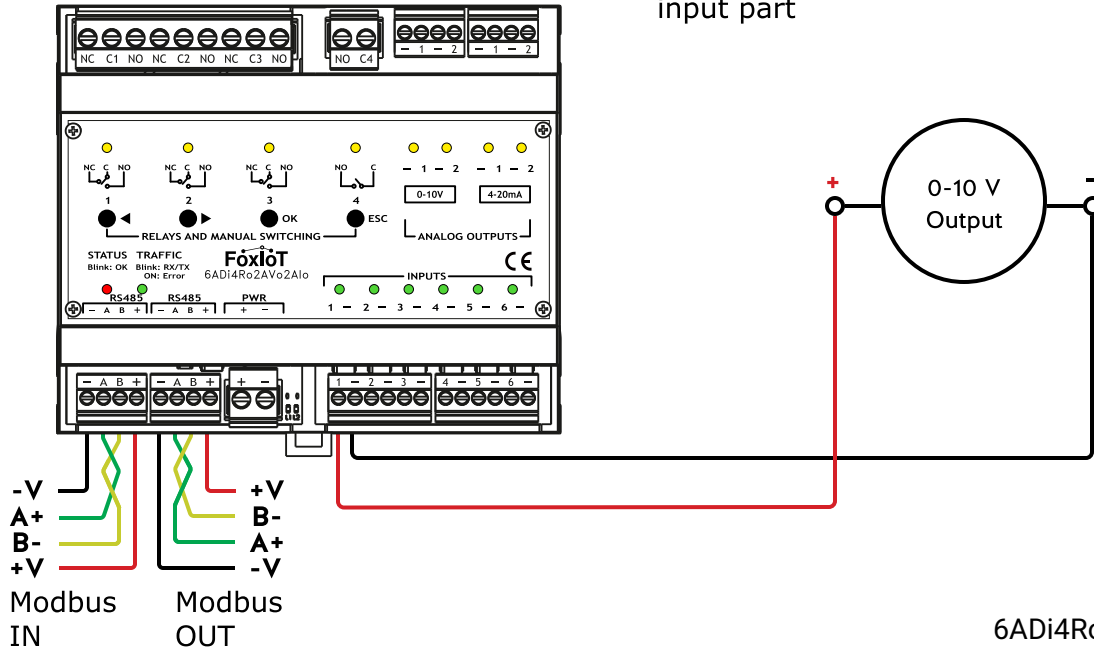

6ADi4Ro2AVo2Alo input connections

Connecting 4..20mA Output with Separate Power Supply

Set Port Mode 1 in Modbus Register (see datasheet)
 Note: The 4..20mA output can be connected to any input port

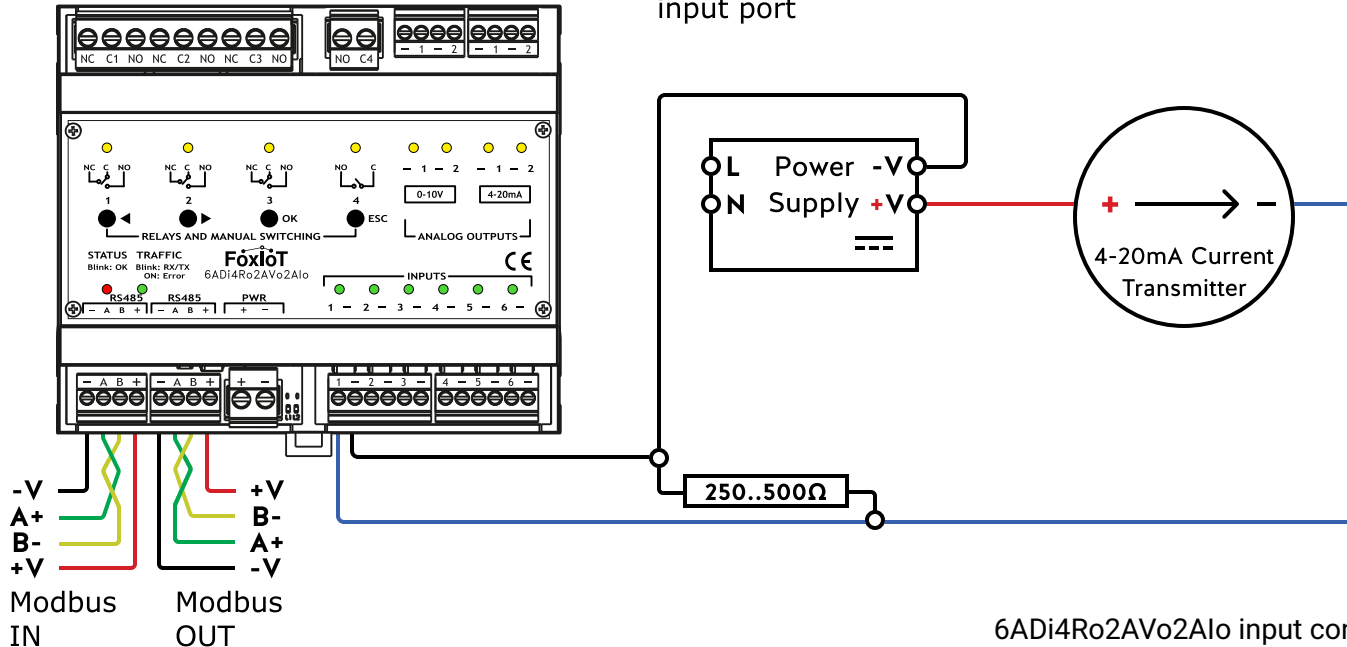

6ADi4Ro2AVo2Al0 input connections

Connecting 4..20mA Output with Shared Power Supply

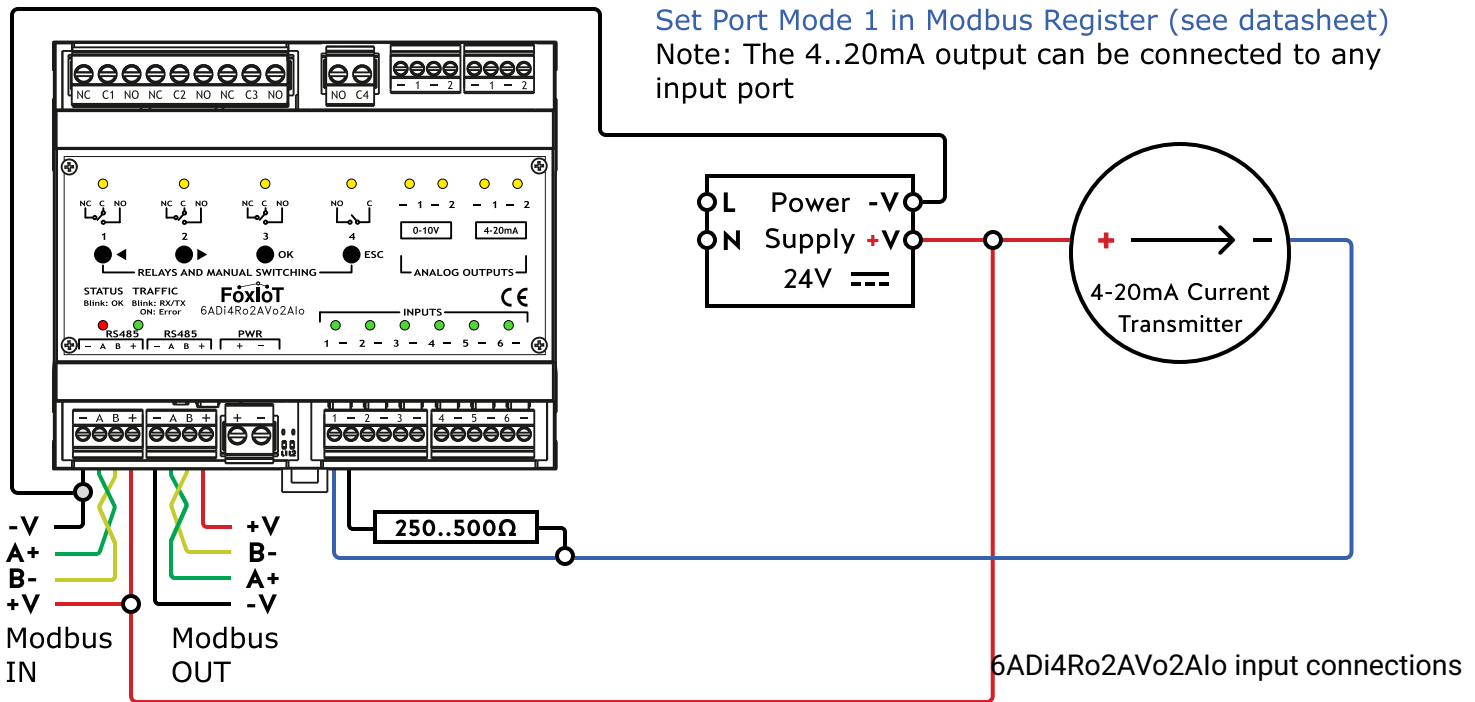

Connecting a Switch or Relay Using Internal Pull-Up

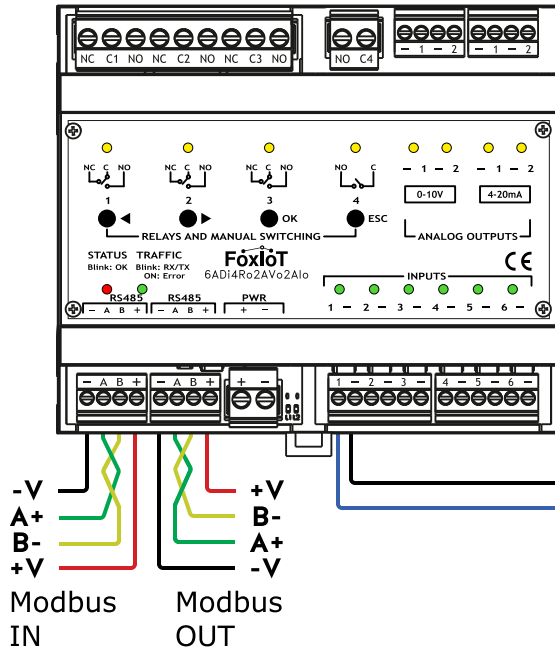

Set Port Mode 0 in Modbus Register (see datasheet)
 Note: The Relay and/or Switch can be connected to any input port

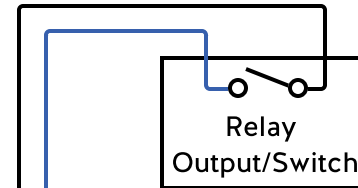

6ADi4Ro2AVo2Alo input connections

Connecting a Switch or Relay with Sourcing Signal and External Pull-Down

Set Port Mode 1 in Modbus Register (see datasheet)

Note: The Relay and/or Switch can be connected to any input port

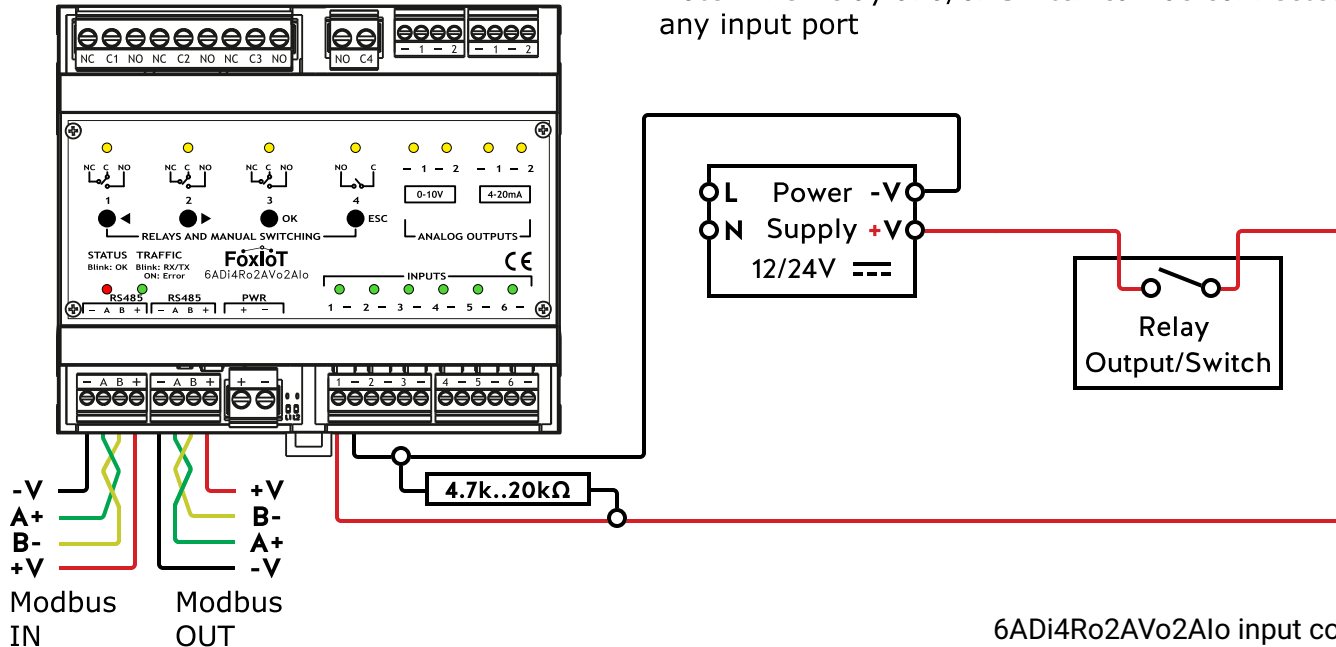

6ADi4Ro2AVo2Alo input connections

Connecting Sink-Type Outputs (Open-Collector/Open-Drain) to a Controller Input

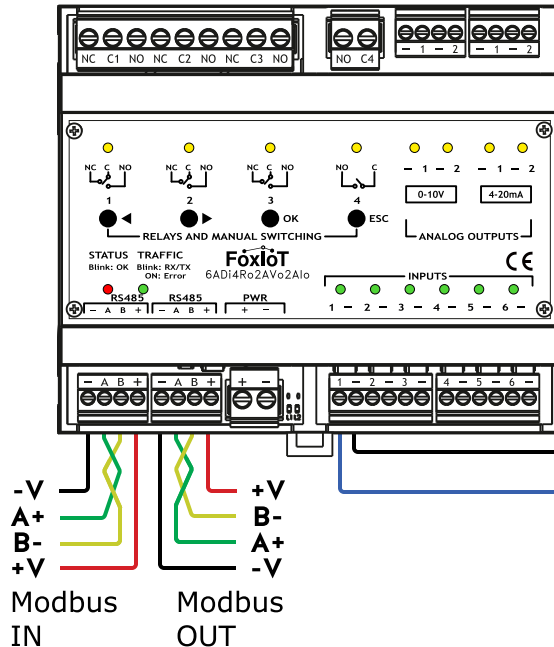

Set Port Mode 0 in Modbus Register (see datasheet)
Note: The Open Collector and/or Open Drain output can be connected to any input port

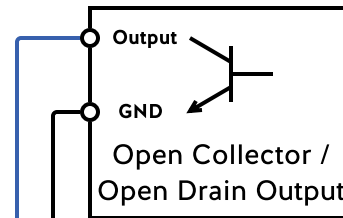

6ADi4Ro2AVo2Al0 input connections

Connecting an NTC 10k Temperature Sensor to Controller Input

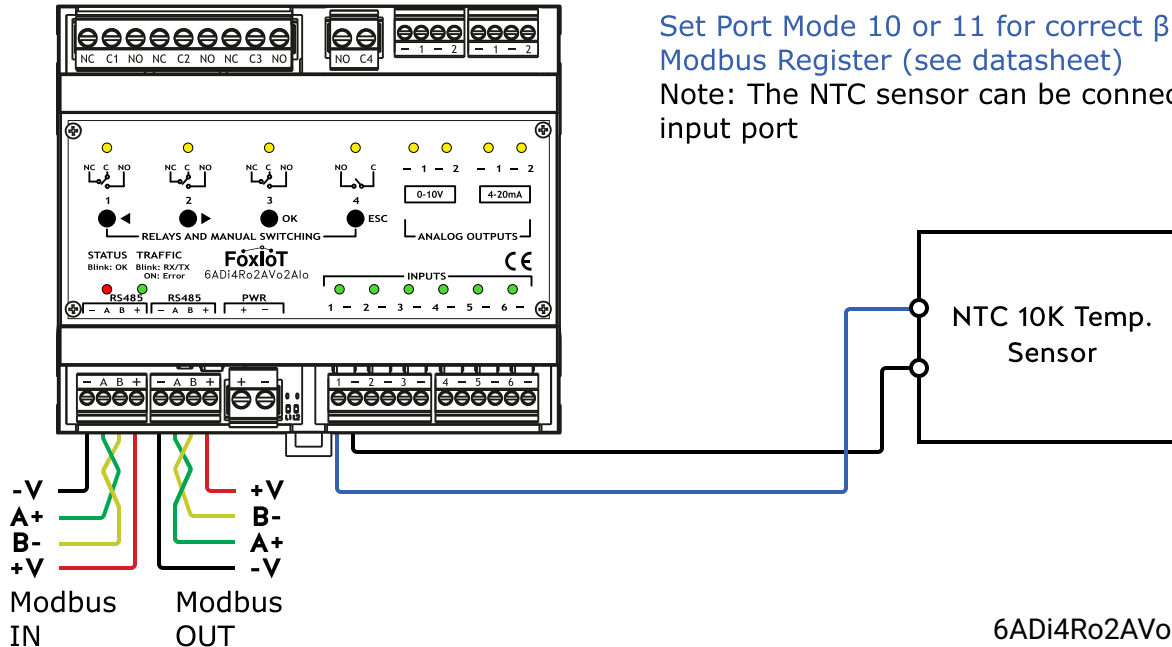

Connecting VFDs (0-10 V) to Analog Output Channels

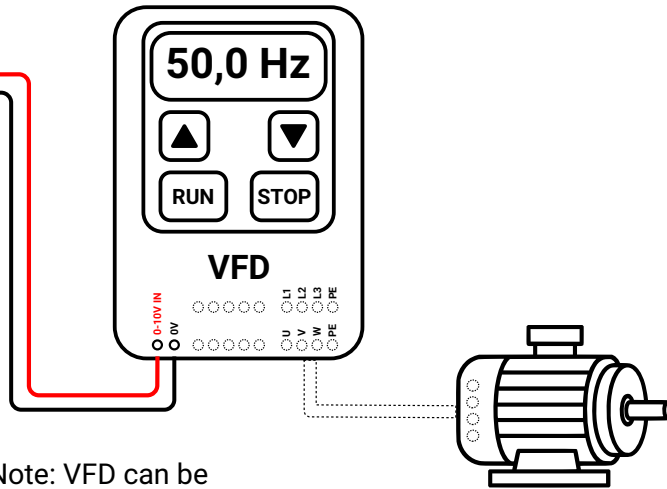
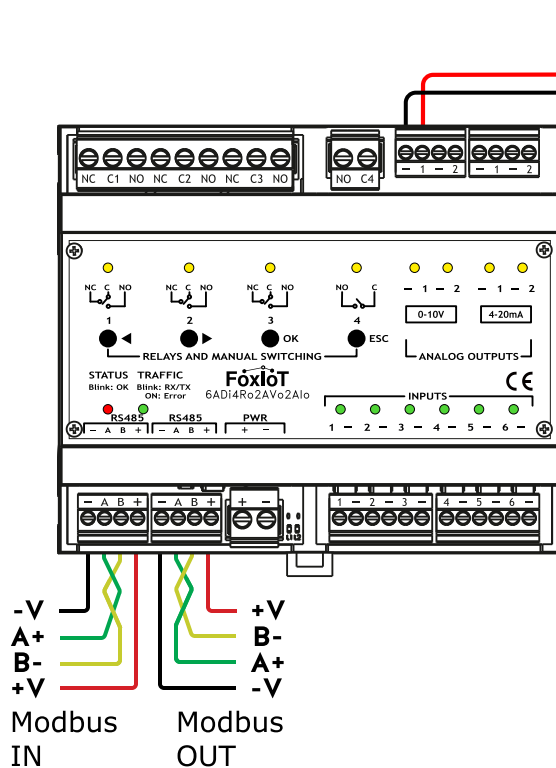

Note: VFD can be connected to any 0-10V analog output port.

6ADi4Ro2AVo2Alo analog output connections

Connecting LED Dimmers (0-10 V) to Analog Output Channels

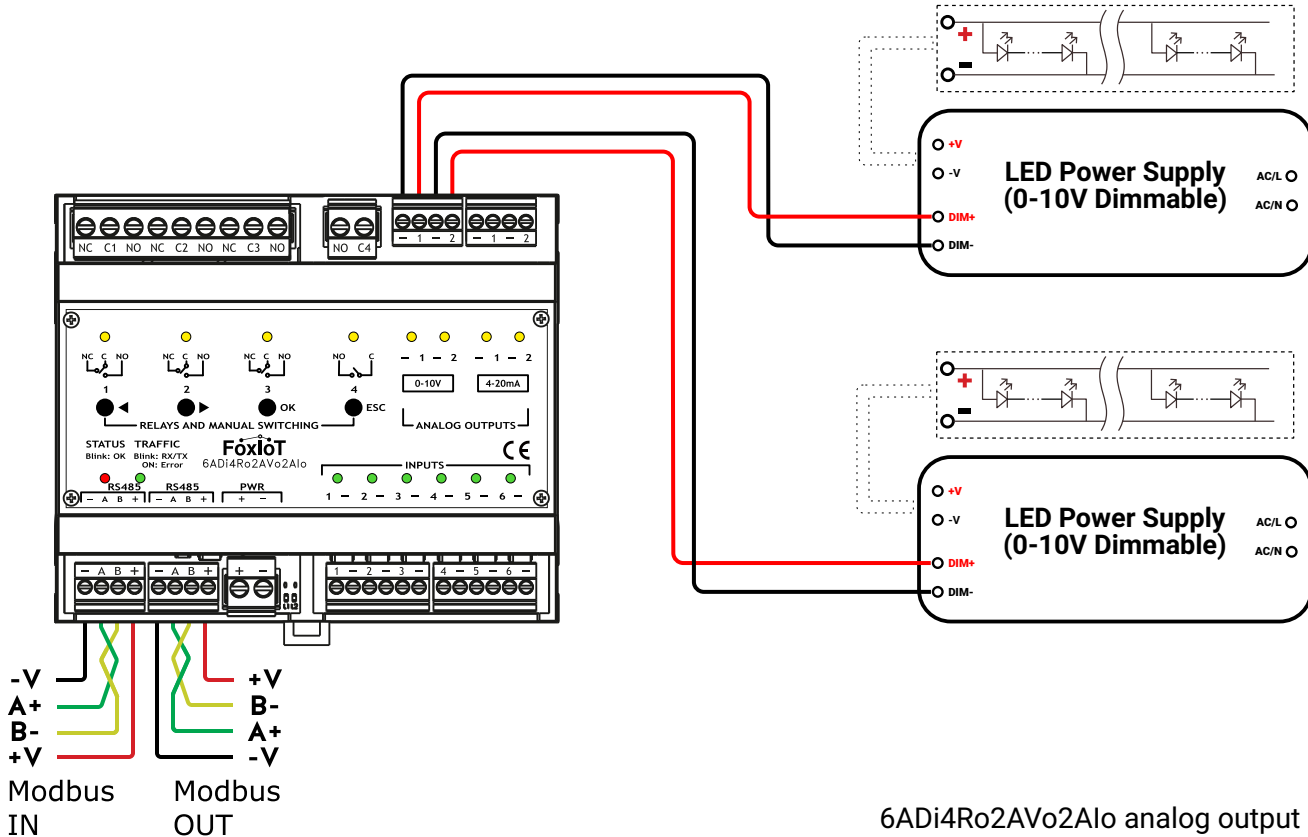

Connecting 2-Way, 3-Way or 4-Way Valves (0-10 V or 4-20 mA)

Note: Valves can be connected to any 0-10V or 4-20mA analog output port.

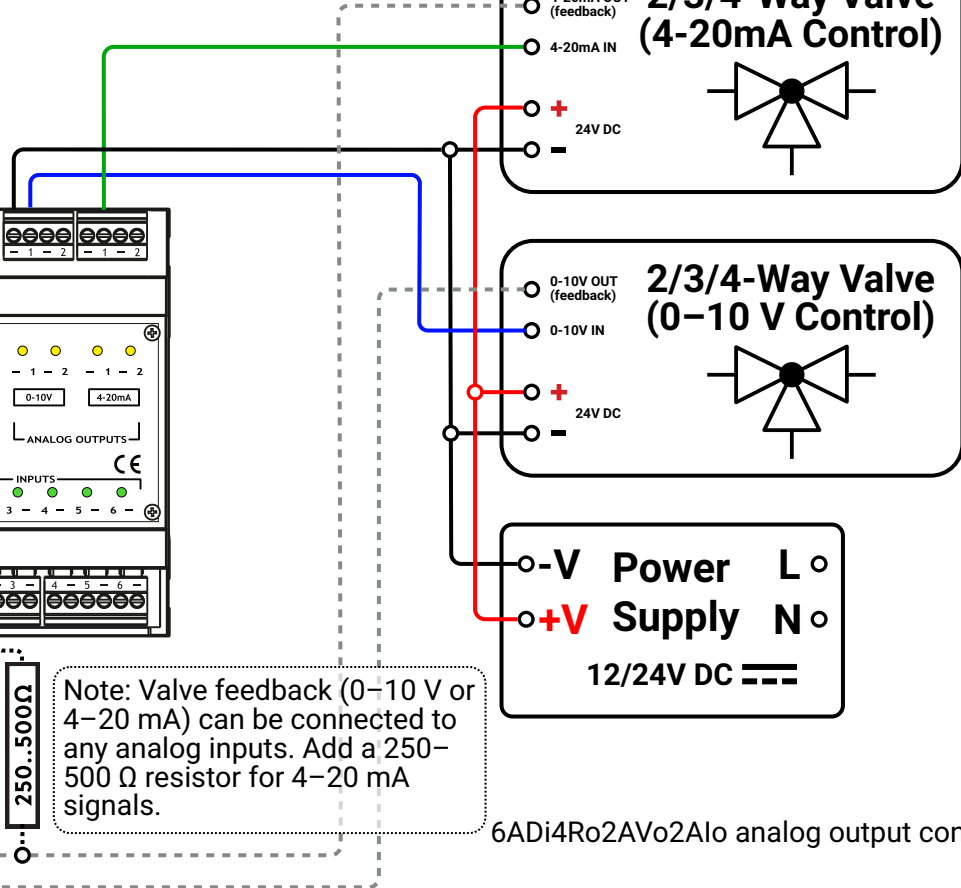
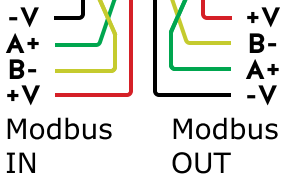
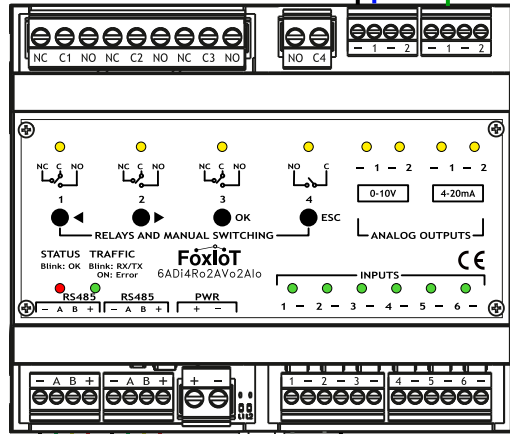

Note: Valve feedback (0-10 V or 4-20 mA) can be connected to any analog inputs. Add a 250-500 Ω resistor for 4-20 mA signals.

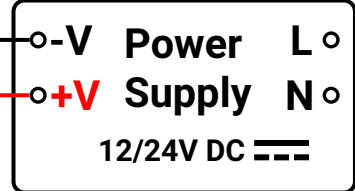

6ADi4Ro2AVo2Alo analog output connections

Sending Analog Signals to External PLCs or Controllers (0-10 V / 4-20 mA)

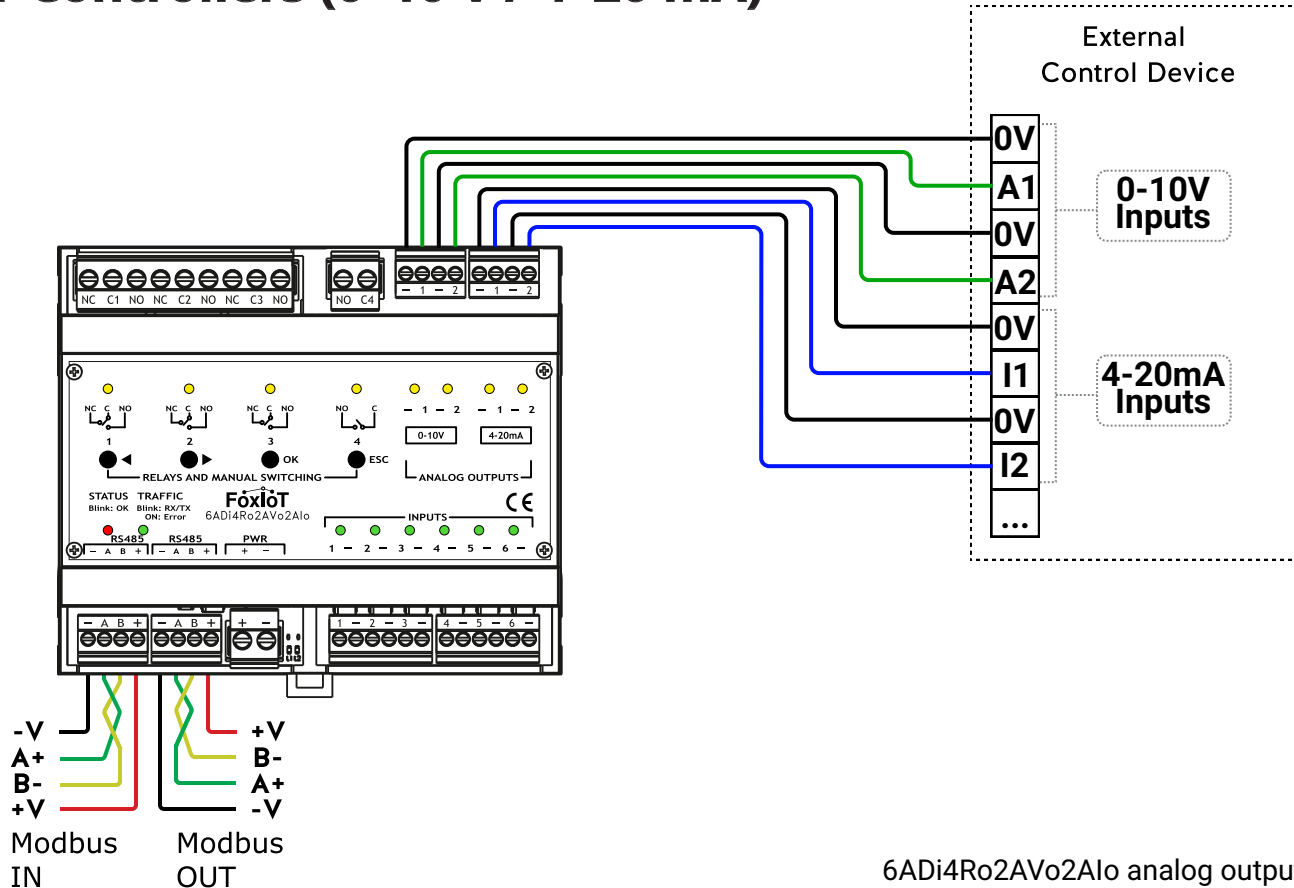

6ADi4Ro2AVo2Alo analog output connections